

STANDARDS & SPECIFICATIONS
FOR THE CONSTRUCTION OF
CURB CUTS AND DRIVE APPROACHES

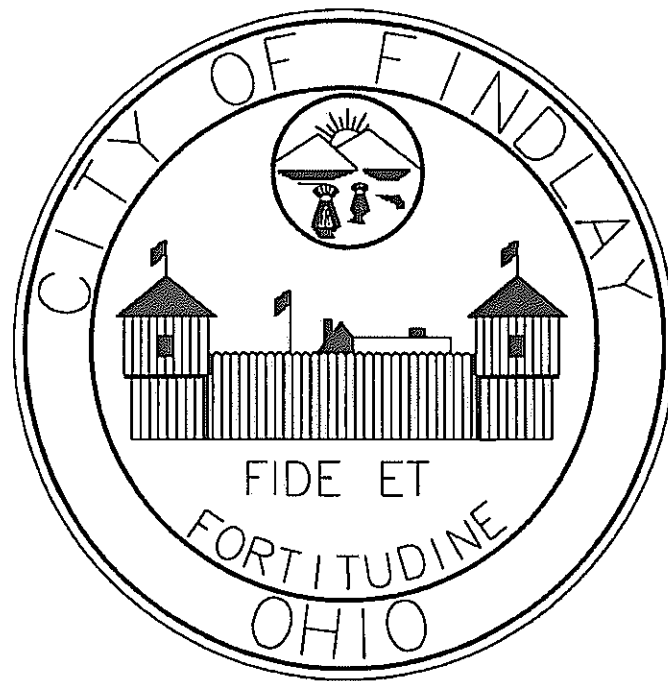

*ADOPTED BY:
THE CITY OF FINDLAY
ENGINEERING DEPARTMENT
EFFECTIVE APRIL 01, 2005*

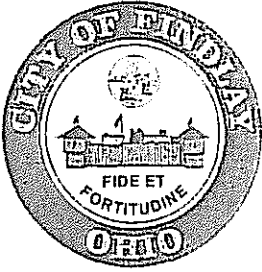

ENGINEERING DEPARTMENT

318 DORNEY PLAZA, ROOM 304

FINDLAY, OH 45840

TELEPHONE: 419-424-7121

FACSIMILE: 419-424-7120

JACQUELINE J. SCHROEDER, P.E.
CHIEF ENGINEER

Revised April 1, 2005

CURB CUT AND DRIVE APPROACH CONSTRUCTION POLICIES

In order to facilitate administration and provide more efficient operations for the City of Findlay, the following statements regard sidewalk construction and inspection services:

Curb Cut Permits and Bonding	Section 1
Curb Cut Construction	Section 2
Drive Approach Construction	Section 3
Standard Drawings	Section 4

SECTION 1: CURB CUT PERMITS AND BONDING

Curb cut permits must be obtained from the Engineering Department for a fee of \$25 (907.06) before work begins. A cash bond or performance bond of \$500 minimum or \$30 per lineal foot of curb cut is required. Bonds will be released when satisfactory curb cut work is completed.

SECTION 2: CURB CUT CONSTRUCTION

The typical residential curb cut is constructed no greater than 24 feet wide. If a width greater than 24 feet is desired, permission from the City Engineer is required. Curb cut shall not encroach onto a neighboring property. Curb shall be saw cut through its full thickness and removed, leaving no less than a $\frac{3}{4}$ -inch reveal above the existing gutter or pavement.

SECTION 3: DRIVE APPROACH CONSTRUCTION

Definition: The term "drive approach" used herein shall refer to the portion of any driveway contained within the public right-of-way.

Residential Drive Approach:

Residential drive approaches shall be constructed of a minimum of 6 inches of ODOT Item No. 452 Non-reinforced Portland Cement Concrete conforming to ODOT Item No. 499, Class C.

Concrete shall be placed on a minimum of 2 inches of compacted aggregate base (ODOT Item No. 304 or Item No. 411). Alternatively, the approach may be constructed of a minimum 2 inches of ODOT Item No. 448 Type 1, Asphalt Concrete Surface Course, PG64-22 Medium Traffic on 6 inches of ODOT Item No. 304 aggregate base or 6 inches of Item No. 411 stabilized crushed aggregate. Other standard construction dimensions and details are included on the Standard Drawings.

Commercial Drive Approach:

Commercial drive approaches shall be constructed of a minimum of 8 inches of ODOT Item No. 452 Non-reinforced Portland Cement Concrete conforming to ODOT Item No. 499 and 511, Class C. Concrete shall be placed on a minimum of 2 inches of compacted aggregate base (ODOT Item No. 304 or Item No. 411). Alternatively, the approach may be constructed of a minimum 1.25 inches of ODOT Item No. 448 Type 1, Asphalt Concrete Surface Course, PG64-22 Medium Traffic on 1.25 inches of ODOT Item No. 448 Type 1, Asphalt Concrete Intermediate Course, PG64-22 Medium Traffic on 8 inches ODOT Item No. 304 compacted aggregate base. Other standard construction dimensions and details are included on the Standard Drawings.

Sidewalk stakes shall be set before driveway construction to facilitate proper grading of the driveway approach.

The transverse slope of the portion of the drive approach where the sidewalk intersects shall match the transverse slope of the sidewalk (3/16" per foot).

** If curb or gutter is in poor condition, contact the Street Department (424-7181) prior to removal for possible cost-sharing in curb replacement.*

SECTION 4: ACCEPTABLE MATERIALS

The following materials are accepted by the City of Findlay for use in curb cut and drive approach construction:

A. Surface

1. Plain Portland Cement Concrete (ODOT Item No. 499 and Item No. 511). Bagged mixes that are available for retail sale **do not** qualify as an acceptable material. Concrete must be of natural color. Decorative stamping or coloring will not be accepted.
2. Asphalt (ODOT Item No. 448)

B. Expansion Joint Filler

1. Rubber Expansion Joint (ASTM D 1751 & D 1752)
2. Fiber Expansion Joint Filler (ASTM D 1751)

3. Polyethylene Closed-Cell Expansion Joint Filler (For use around small radii such as manholes, valve boxes, hydrants, etc.)

C. Curing Compounds

1. Curing compound conforming to ODOT Item No. 705.07

SECTION 5: STANDARD DRAWINGS

The following pages include City of Findlay standard drawings for curb cut and drive approach construction.

A. Curb Cut

1. Typical Curb Cut
2. Typical Concrete Curb

B. Drive Approach

1. Concrete Drive Approach
2. Asphalt Drive Approach

TYPICAL CURB CUT FOR DRIVES

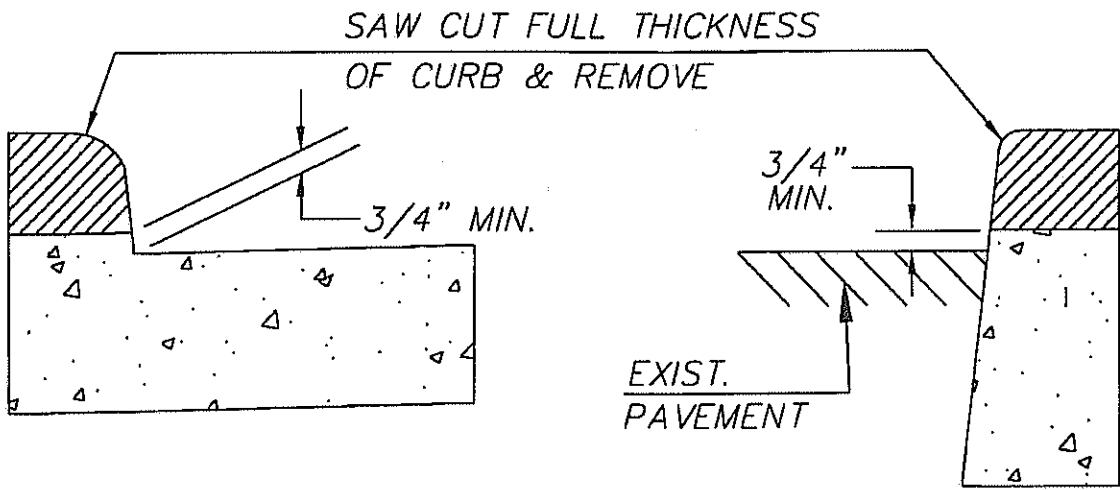
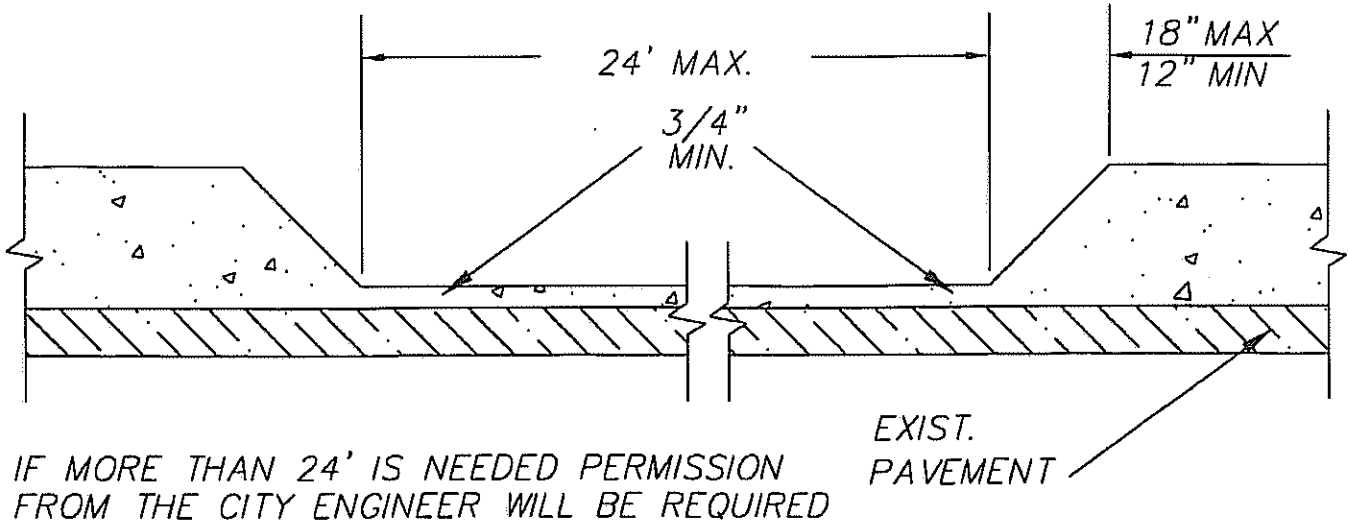

TYPE "C"

TYPE "B"

CURB CUT DETAILS
(FOR VEHICULAR DRIVEWAYS)

APRIL 26, 2004



TYPICAL CONCRETE CURB

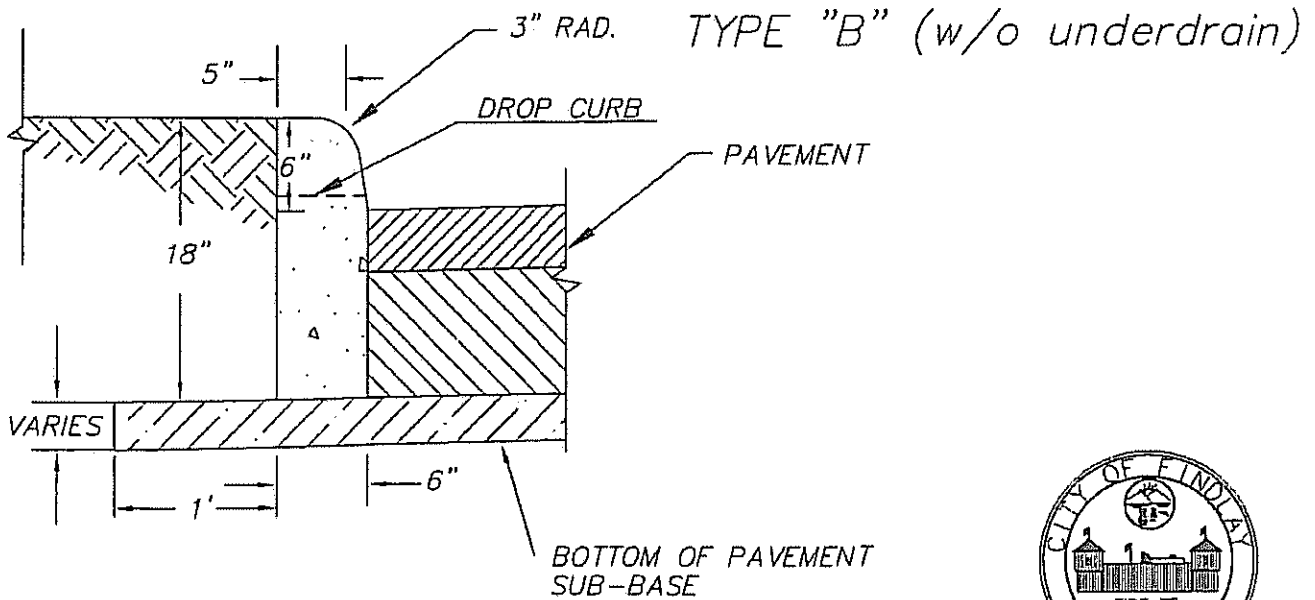
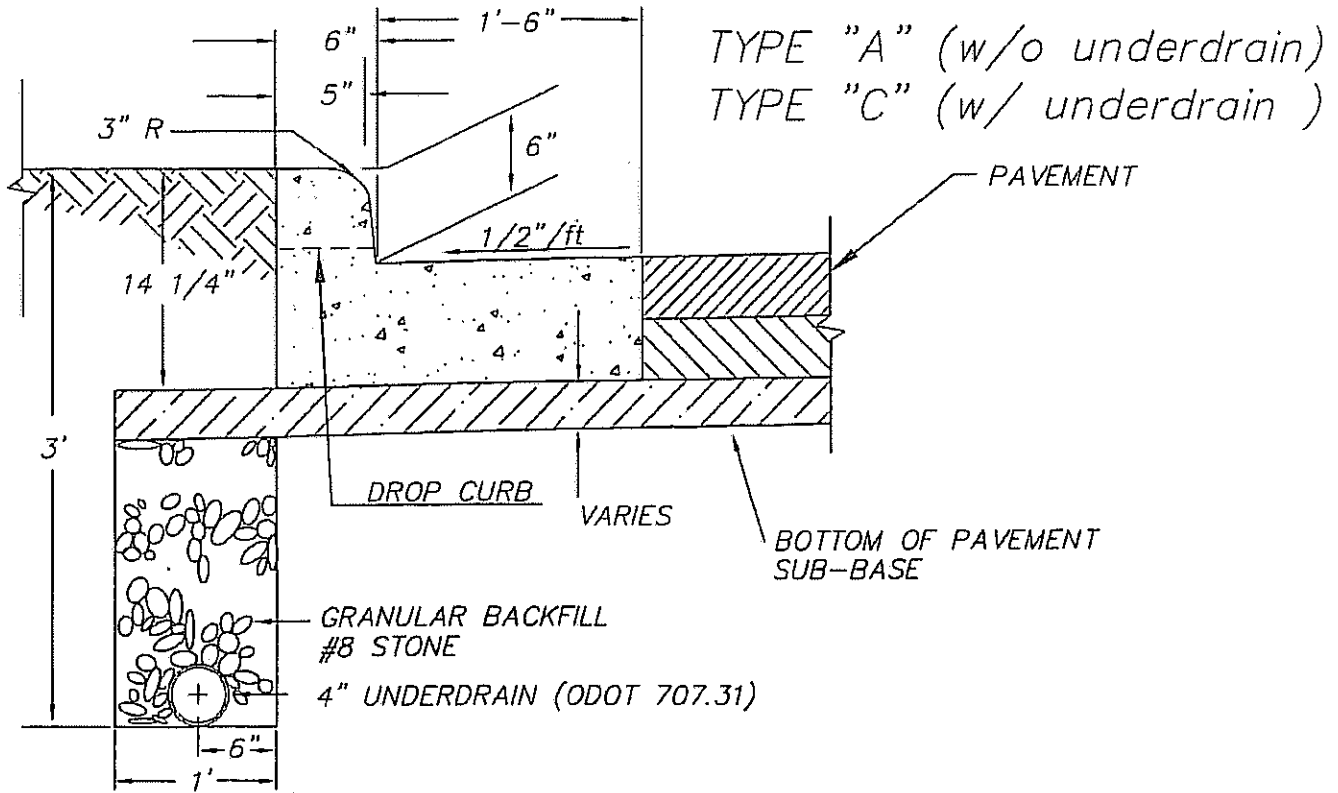

CURB DETAILS
 MARCH 01, 2003

CONCRETE DRIVE APPROACH

MARCH 01, 2003

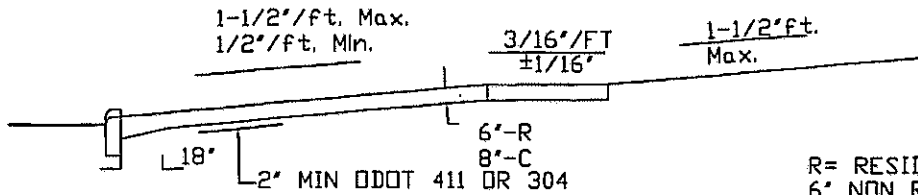

Section A-A

R= RESIDENTIAL DRIVES
 6" NON REINFORCED PORTLAND
 CEMENT CONCRETE PAVEMENT
 ON 2" ODOT ITEM 411 OR
 304 AGGREGATE BASE

C= COMMERCIAL DRIVES
 8" NON REINFORCED PORTLAND
 CEMENT CONCRETE PAVEMENT
 ON 2" ODOT ITEM 411 OR
 304 AGGREGATE BASE



Section C-C

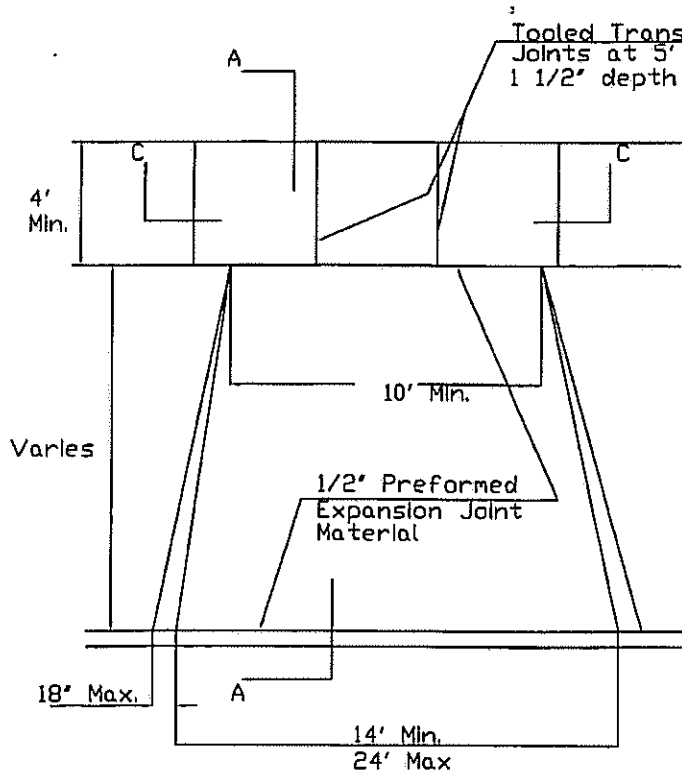

Standard surface texture
 broomed transverse to
 approach slope.

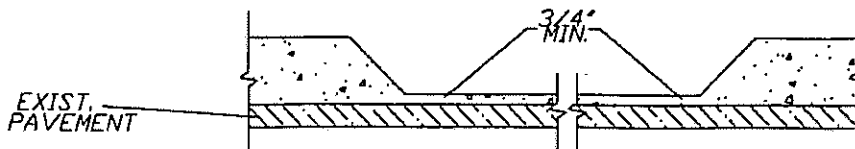

ASPHALT DRIVE APPROACH

MARCH 01, 2003

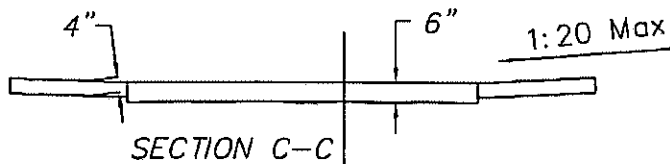
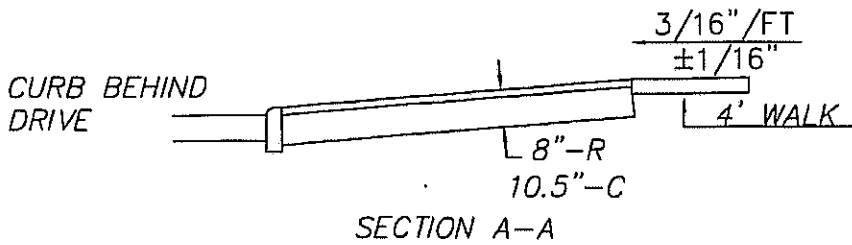

TOOLED TRANSVERSE
CONTRACTION JOINTS
OF 5' INTERVALS, 1 1/2"
DEPTH

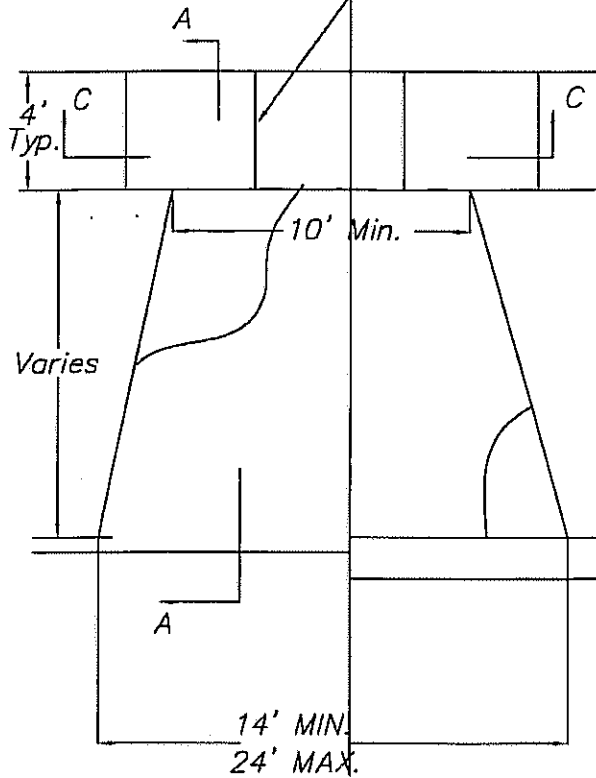

R= RESIDENTIAL DRIVES

- 2" ODOT ITEM 448 TYPE 1,
ASPHALT CONCRETE SURFACE
COURSE, PG 64-22
MEDIUM TRAFFIC
- 6" ODOT ITEM 304 OR
6" ODOT ITEM 411
AGGREGATE BASE

C= COMMERCIAL DRIVES

- 1.25" ODOT ITEM 448 TYPE 1,
ASPHALT CONCRETE SURFACE
COURSE, PG 64-22
MEDIUM TRAFFIC
- 1.25" ODOT ITEM 448 TYPE 1,
ASPHALT CONCRETE INTERMEDIATE
COURSE, PG 64-22
MEDIUM TRAFFIC
- 8" ODOT ITEM 304

